











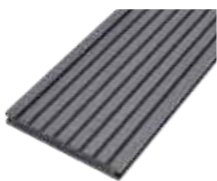

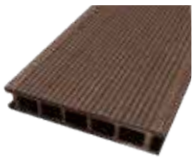

DECKING BOARDS

INSTALLATION AND MAINTENANCE RECOMMENDATIONS

MATERIALS

The offer includes the following basic materials:

NAME	PICTURE	DIMENSIONS (mm)
FULL TERRACE BOARD (composite profile)		20 x 160 x 3000 or 20 x 160 x 4000 or lengths on order
TERRACE BOARD (composite profile)		25 x 160 x 3000 or 25 x 160 x 4000 or lengths on order
TERRACE BOARD (composite profile)		ECO: 25 x 140 x 3000 25 x 140 x 4000 ELEGANCE: 25 x 140 x 4000
JOIST (composite profile)		30 x 50 x 3000
JOIST (aluminum profile)		36,4 x 24 x 4000
HIGH JOIST (aluminum profile)		39 x 50 x 4000
FINISHING STRIP „L” SHAPE (ANODIZED)		35 x 35 x 3600
COMPOSITE FINISHING PROFILE (composite profile)		60 x 6 x 3000
WPC FINISHING STRIP „L” SHAPE		35 x 60 x 3000

NAME	PICTURE	DIMENSIONS (mm)
MOUNTING CLIPS		Kit for 2 m ² 32 pcs of mounting clips 3 pcs of start clips
		Kit for 10 m ² 160 pcs of mounting clips 15 pcs of start clips
MOUNTING CLIPS 6 mm		Kit for 2 m ² 32 pcs Kit for 10 m ² 160 pcs
GAMRAT WPC ABS POLYMER CLIPS with SCREW 6mm		Kit for 2 m ² 32 pcs Kit for 10 m ² 160 pcs
TORX SCREW		27 x 3,8
TORX T15 50 mm		-

GAMRAT composite profiles are high quality materials containing selected meal in its composition wood and plastic (PVC) with the necessary additives. Elements these are only for making terraces and cannot be used for other construction purposes without execution of the project by persons authorized to do so. Gamrat also offers various types of leveling elements or giving the terrace an appropriate slope by raising it to the required height.

GAMRAT also offers different kinds of elements for levelling or obtaining a proper decline of a terrace by raising it to the required height.

Colouring

In the first period of use, composite profiles under the influence seasonal conditions. The color stabilizes after a few months reaching final saturation. Unbrushed boards after During the seasoning period, they undergo a matting process, which makes them visually closer for the brushed version. Due to the content of wood fibers, individual composite profiles, especially those from different production batches, may differ in color. Colors and surface finishes may be different in different deliveries. This does not affect their durability and this is not a product defect. Before proceeding with the assembly, you must visually assess the appearance of composite profiles whether they are free from defects. To achieve a natural effect, composite boards must be moved before installation, remembering the brushing direction

Substrate preparation

Terraces, stairs, communication paths made of composite profiles Gamrat is mounted on a previously prepared substrate, the implementation of which should be in accordance with the current knowledge and building regulations. Very often a preparation project is necessary substrate to maintain maximum future safety users. The execution of the substrate is carried out at the sole responsibility contractors and the information provided below is for reference only informative.

This manual has been prepared for standard board lengths and joists of 3 m.

The most common solutions include:

- 1) Concrete substrate, reinforced concrete;
- 2) Substrate on the ground;
- 3) Substrate on a balcony or inverted roof structure with waterproofing.

In any case, regardless of the type of substrate and the joist used for the construction of terrace boards, joist spacing which the directly mounted boards will rest on, must be equal to maximum 40 or 45 cm * „in the light” (for WPC Gamrat joists). At the same time, it is necessary to ensure that the board is fastened with clips as much as possible every 50 cm, which is automatically included in the joists of the system Gamrat WPC. At the beginning and end of the planks to provide extra stabilization and proper work, the first row of joists should be compacted and this distance should be 20 cm „in the light”. The structure should be closed with a frame within the terrace outline.

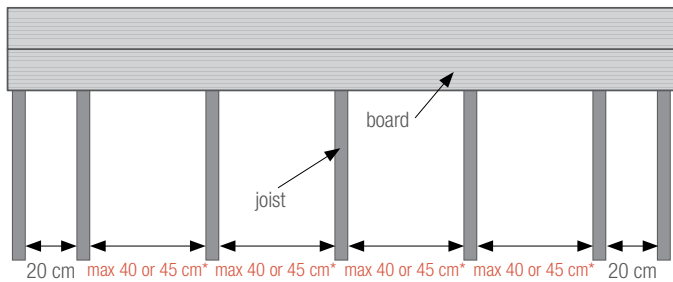

spacing of joists

- *40 cm - full decking board
- *45 cm - hollow decking board

1) CONCRETE SUBSTRATE, REINFORCED CONCRETE:

- The terrace is mounted on composite joists attached to the substrate.

Lay joists on a concrete slab (do not embed them in the concrete), fixing with concrete dowels or elastomeric adhesive. It is allowed to install joists arranged vertically using an elastomeric adhesive (only on flat surfaces, adjacent on the entire length of the joist to the ground).

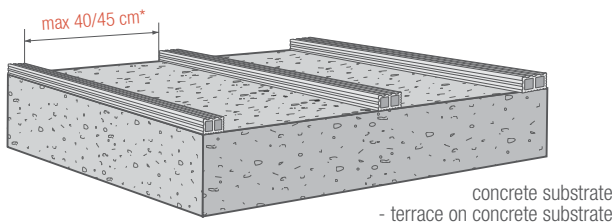

- *40 cm - full decking board
- *45 cm - hollow decking board

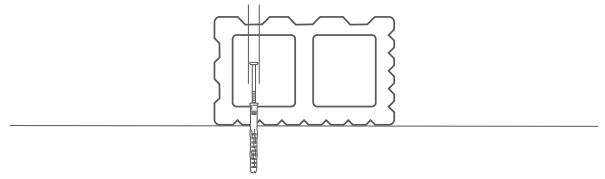

The joists can also be placed on a steel, wooden or aluminum structure or on plastic supports or concrete cubes. All these types of supports must be permanently attached to the ground. The composite joist must be fixed (drilled, with a dowel or using 90o carpentry joints). Maximal the distance between the support points of the composite joists it's 35cm. The ground must be flat and stable with a minimum slope of 1% from the outside of the building. Such an inclination of the terrace affects optimal drainage of water from its surface.

2a) SUBSTRATE ON GROUND:

- The terrace is installed on concrete foundations with a wooden or metal structure with a higher load capacity than the WPC joist.

In this case, drill holes to a depth below the frost line ground. Depending on the region, it is about 1.0 m deep - 1.2 m. It is advisable to reinforce the openings with wire and pour concrete. Above in the center of the holes made, e.g. cardboard ones should be placed concrete covers to the height of the planned terrace (taking into account the thickness of the joist and the thickness of the board), make the whole thing in the recommended slope terrace (min. 1%) and pour concrete. Distances between each pillars/joist support points depends on the type used material from which the construction will be made. Usually used such a wooden or metal joist profile so that the distance between concrete pillars could be approx. 0.7 m.

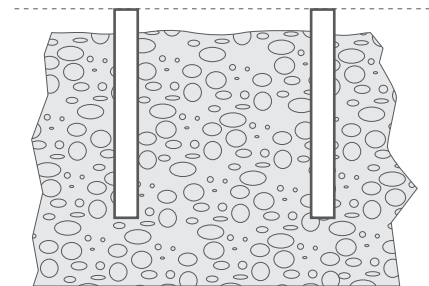

substrate on ground
- terrace on concrete supports

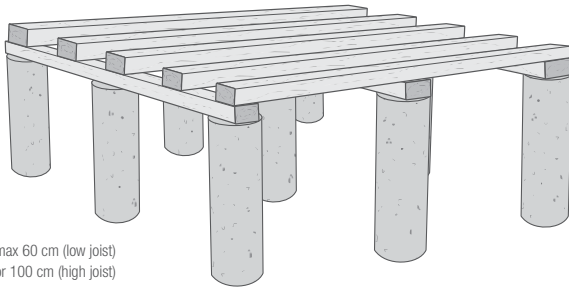

max 60 cm (low joist)
or 100 cm (high joist)

substrate on ground
- terrace on concrete supports and wooden structure

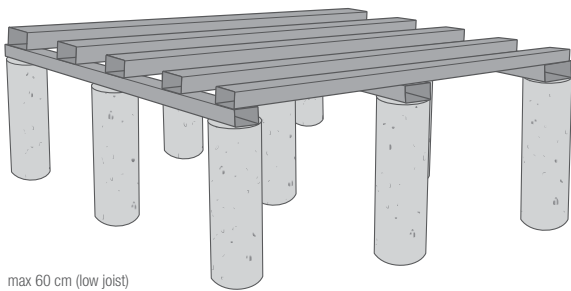

max 60 cm (low joist)
or 100 cm (high joist)

substrate on ground
- terrace on concrete supports and metal structure



low aluminum joist
- spacing of supports max. every 60 cm



high aluminum joist
- spacing of supports max. every 100 cm

2b) SUBSTRATE ON GROUND:

• Terrace installed on concrete slabs.

In order to make the substrate in this way, the layer must be removed soil to a depth of approx. 20 - 30 cm, and put gravel in this place. Compact the whole in a way that prevents further settling of stones. Concrete slabs should be placed on the prepared substrate such a distance apart that there is free space between the points support of the joists did not exceed 35 cm in the case of the WPC joist and correspondingly more when used for the construction of joists made of a material with a greater load capacity than a composite joist. joists must be permanently attached to the concrete slabs. Weight concrete slabs must be large enough to provide adequate stability and maintenance of the structure. **In this case, you should take into account the possibility of ground movement in winter, which will translate into the surface of the terrace, for which Gamrat takes no responsibility.**

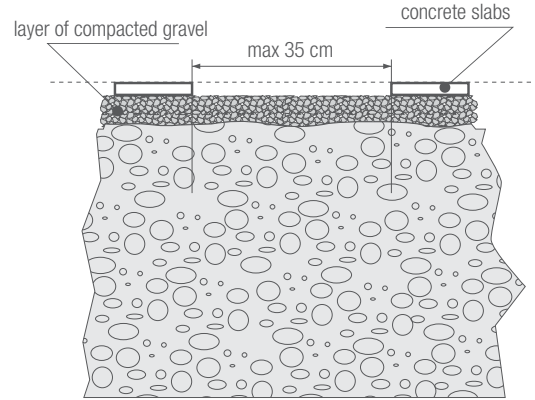

substrate on ground
- terrace on concrete slabs

3) SUBSTRATE ON A BALCONY OR STRUCTURE OF AN INVERTED ROOF WITH WATERPROOFING:

- Install the floating terrace on a metal grate.

In the case of floating terraces, where there is no possibility to penetrate directly into the ground, which takes place where horizontal waterproofing is made, e.g. balconies, garages, etc. Boards must be laid on a suitable self-supporting structure in the form truss made of steel or aluminum joists o a suitable profile that will take over the work of the terrace and stiffen it him. The first layer of joists on the lower or most often on the upper ones points of support in the form of adjustable brackets or concrete blocks, properly leveled. Next the second cross layer of steel or aluminum joists with preservation spacing under the boards max 40 or 45 cm* between. In in this case, the compaction of the first row is particularly important joists at a spacing of 20 cm. This is to provide extra stabilization and operation of a structure that is not permanently attached to the ground. We remember further about the requirement to fasten the board with clips maximum every 50 cm.

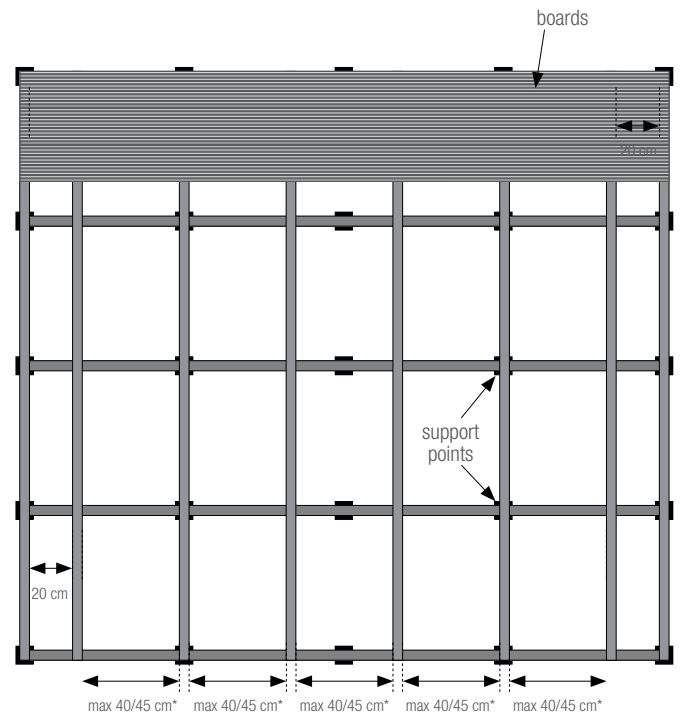

Floating terrace on a metal truss

spacing of joists

*40 cm - full board | *45 cm - chamber board

Note:

• When preparing the substrate, pay attention to looseness drainage of water outside the terrace area. This applies to both terraces made at ground level as well as above-ground terraces. In order to facilitate the drainage of water, it is recommended to make a slope from the building at least 1%, i.e.: 1 cm per 1 m. This applies to both terrace boards, as well as the structures on which they are mounted joists.

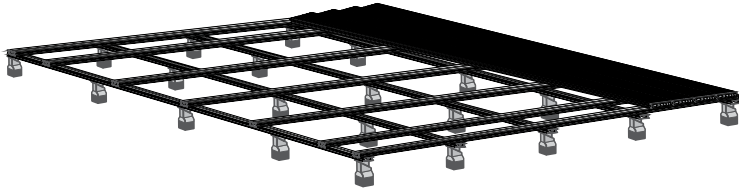

Floating terrace on a metal truss laid on levelling plastic supports

1) HORIZONTAL AND VERTICAL POSITIONING OF JOISTS AND EXPANSIONS GAPS

Joists shall be laid parallel to each other (except for cutting terraces at an angle of 45°). It is allowed to lay joists in the horizontal position, which causes the terrace to be additionally raised by about 3 cm or in the vertical position, which causes the terrace to be additionally raised by about 5 cm (joist of dimensions 3 x 5 cm).

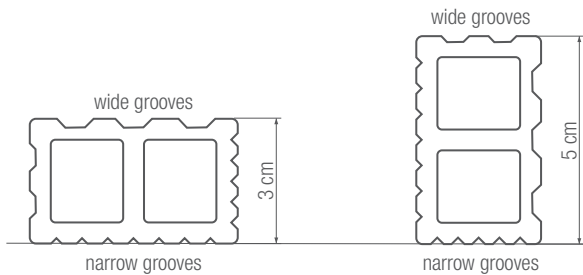

aying should be done so that the joists lie flat and wide rooved up. These grooves are prepared so that the mounting clips t in the grooves of the profile, which will be helpful in the further ssembly stage. Be sure to leave between the wall nd the joist 1-2 cm. To ensure good drainage of surface water nder the terrace, a gap of 1 cm should be made at the frontal one oining joists. These expansion joints are essential for roper behavior of the elements during use and or free drainage of water under the boards.

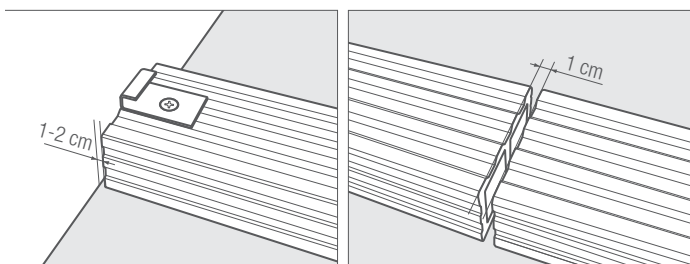

2) FIXING JOISTS TO SUBSTRATE

The joists should be permanently attached to the ground with pegs expansion bolts (not included). For this you need a drill larger than the head of the pin, drill through the top joist. Then through the hole made with a widia drill with a diameter adapted to the size of the expansion plug should be made hole in the bottom of the joist. Screw it through the holes made joist to the ground with an expansion bolt. It is possible to use pins for quick assembly, which significantly shortens the time of attaching the joists Gamrat, is 50 cm.

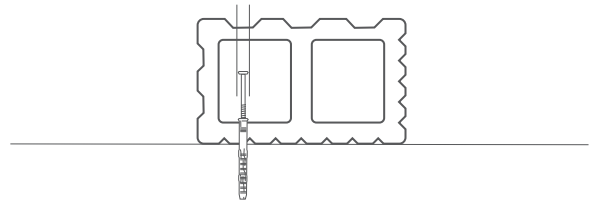

joist fastening in a horizontal arrangement

3) SPACING AND ARRANGEMENT OF JOISTS

Maximum distance between joists (board support points) must not exceed 40 or 45 cm* at any point, and each a single joist, regardless of its length, must have a minimum 3 support points not exceeding 35 cm.

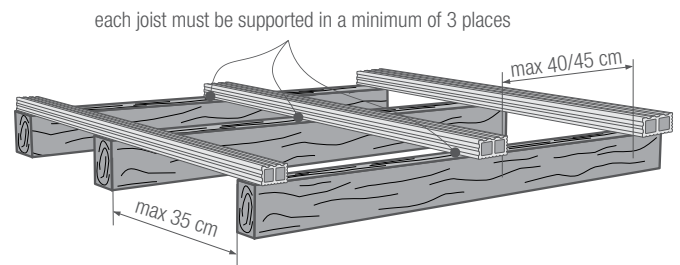

each joist must be supported in a minimum of 3 places

spacing of joists

- *40 cm - full decking board
- *45 cm - hollow decking board

If it is necessary to join the boards face-on or to make them bevels of the terrace, remember to install an additional one joist so that the ends of each plank rest on a separate one joists and were attached with separate clips.

LAYING TERRACE BOARDS

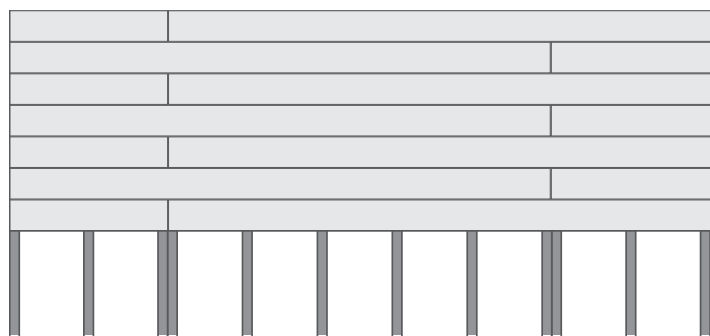

arrangement of joists when using butt joints of boards - terrace with a staggered arrangement

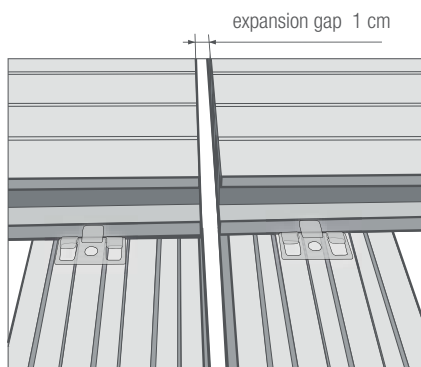

boards joined using a butt joint and supported by two joists

* All mounting clips from the Gamrat WPC offer can be used interchangeably.

When performing non-standard joints, for example, corners at an angle of 45°, joist shall be placed under each board separately, so that the ends of boards are supported on a separate joist. Remember to leave a 1 cm gap between the boards and joists to allow free expansion of the material.

Notes:

- Do not place joists in a vertical position on point bases (e.g. concrete slabs, plastic supports, etc.).
- In the case of floating structures, it is recommended to use joists aluminum only
- It is also allowed to lay terrace boards directly on wooden, aluminum or galvanized steel profiles. In this case, follow the manufacturer's guidelines these profiles, because each manufacturer, depending on their dimensions and e.g. wall thicknesses may recommend different distances in between support points. By default, however, it is assumed that points supports for the aluminum profile: - 30x30 mm and a wall thickness of 2.0 mm is 50 cm, - 30x50 mm and wall thicknesses of 2.0 mm are 80 cm (when laid to a height of 50 mm).
- In the case of wooden joists, use appropriately prepared and impregnated elements made from hardwoods or exotic woods. Use of soft wood joists (e.g. pine) will cause them to rot too early, which will lead to damage the terrace. In neither of these cases did Gamrat takes responsibility for the durability and stability of the entire structure.
- Please note that the maximum distance between joists (points board support) must not exceed 40 or 45 cm* counting from the edge of adjacent joists (i.e. clearance between joists) a the distance between the clips must not exceed 50 cm. **40 cm - full board, 45 cm - hollow board**
- For heavy traffic (e.g.: pedestrian communication road, stairs) or occurrence of significant concentrated forces on the terrace (e.g.: placing heavier objects on the terrace) the distance between support points of the joists and the distances between them should be thickened accordingly.
- To increase the support surface of the joists and thus foam can be used to increase the stability of the entire structure low-expansion polyurethane, dosing it between the joist and the ground over the greatest possible length of the joists.

LAYING TERRACE BOARDS

1) TYPES OF GROOVES AND ARRANGEMENT OF BOARDS

Gamrat composite profiles - 16 cm wide terrace boards (chambered and solid) are two-sided products. On the one hand they have a wide groove. The other side of the chamber board has a groove narrow and the other side of the solid plank is flat.

The 14 cm wide terrace board is a one-sided product. On the usable surface, it has grooves of a characteristic shape.

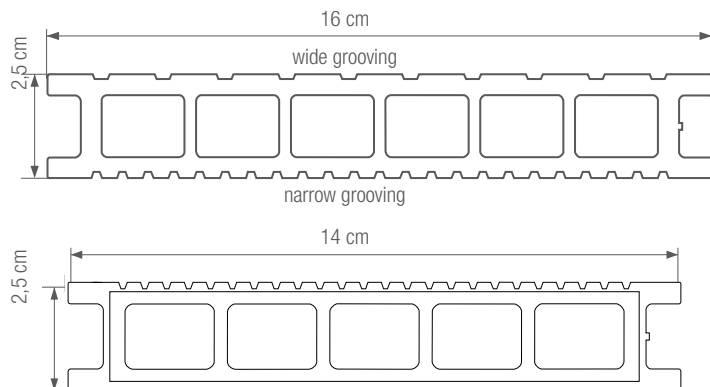

On one side of the terrace board there is a printed one an inscription clearly identifying the product, and a tab on the other – marker. When assembling, make sure that the inscription or the marker was always on one side of the assembled terrace. This ensures that the boards will be laid with this in mind brushing direction. This arrangement minimizes the - the occurrence of shade differences after installation and over time using

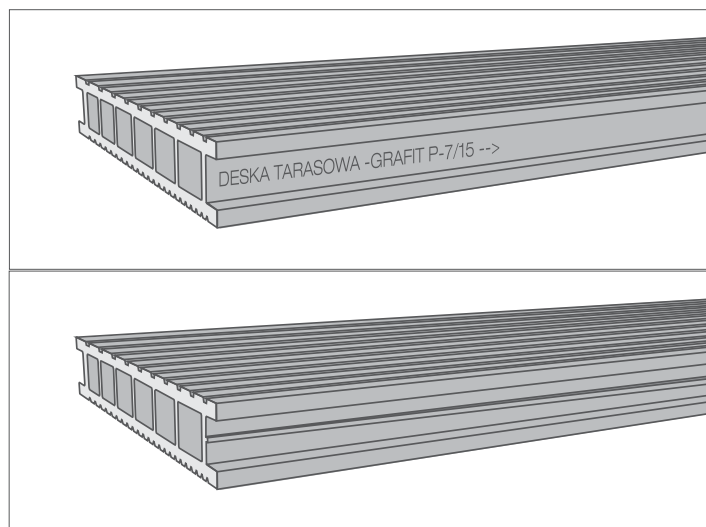

2) FASTENING BOARDS

Fastening boards to joists is done using the supplied mounting kit. The set includes screws, start clips – for installing the first board, and mounting clips – for fastening subsequent boards. When using joists other than system joists, appropriate screws should be used to fasten boards with mounting clips. The screws attached to the kit are screws for a WPC joist. In the case of using wooden or metal joists, you need to obtain appropriate screws on your own.

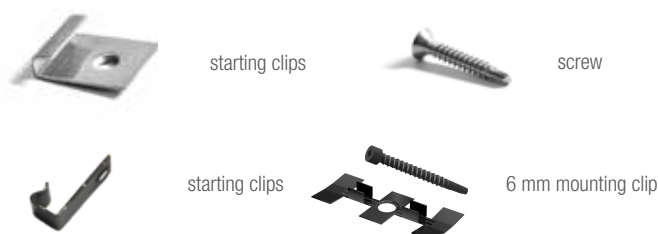

LAYING TERRACE BOARDS

Start installing a board from fastening start clips to the joist. You shall leave an expansion gap of min. 1-2 cm between the board and the wall.

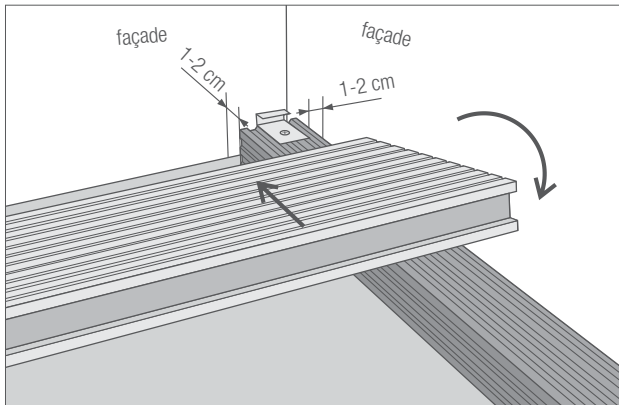

installation of the first board with a start clip

After fastening the start clips, place a board to have its lower tongue properly fixed by the start clip. Push the board into its place and screw in the second edge of the board using a mounting clip. It should be noted that in order to facilitate the installation, the hole in the clip is made as an eccentric one. This allows you to freely screw the clip in before placing the next board.

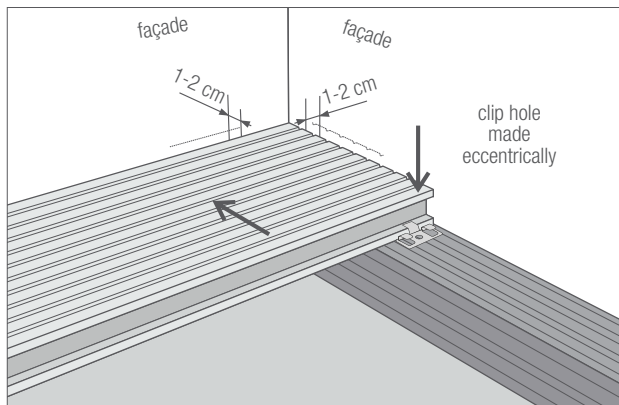

installation of the first board with a mounting clip

*** All mounting clips from the Gamrat WPC offer can be used interchangeably.**

Clips are designed so that there is an expansion gap of 0.5 cm between the subsequent boards.

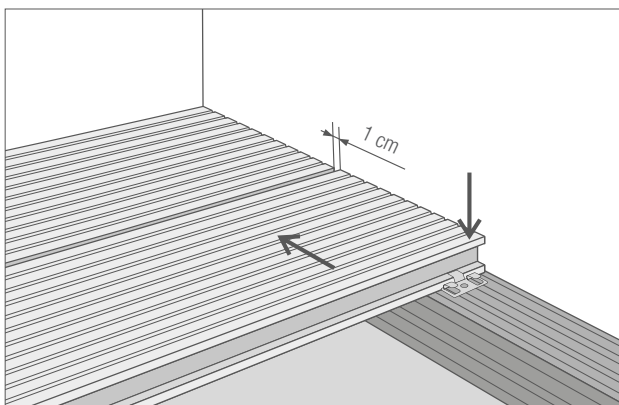

installation of a subsequent board with a mounting clip

*** All mounting clips from the Gamrat WPC offer can be used interchangeably.**

In the event of connecting boards using a butt joint, pay attention to that the expansion gap there between is 1 cm.

LAYING TERRACE BOARDS

The ends of the boards must rest on separate joists and be secured by separate clips. For a better appearance, it is recommended to cut off approximately 10 mm from both ends of the board before its installation, as they are slightly rounded after brushing.

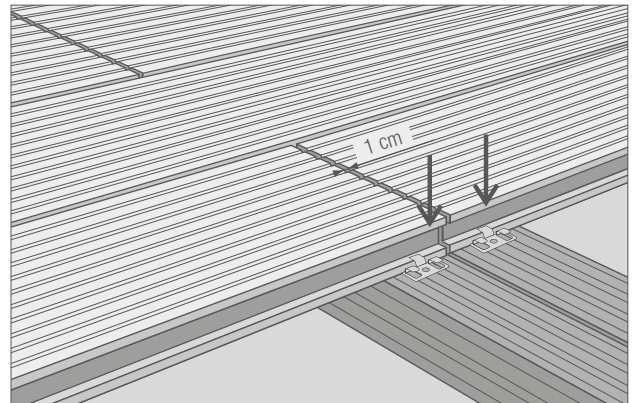

butt joint of boards on two separate joists (expansion gap 1 cm)

*** All mounting clips from the Gamrat WPC offer can be used interchangeably.**

The installation of the last board shall be performed by screwing the screw at an angle through the bottom edge of the board to the joist. There is a possibility of cutting a board lengthwise, crosswise and at an angle. To do this, use widely available professional tools like for cutting wood planks.

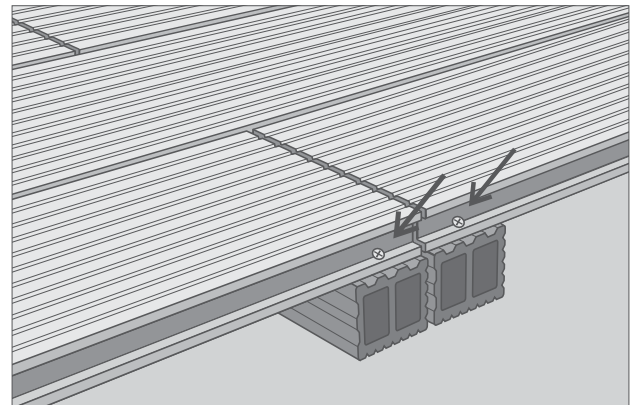

installation of the last boards with screws screwed at an angle

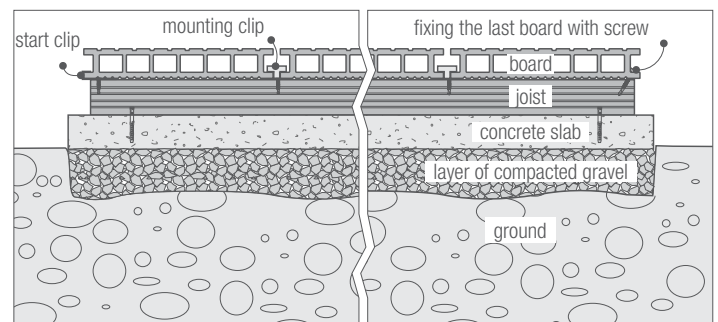

terrace view from the fronts of boards

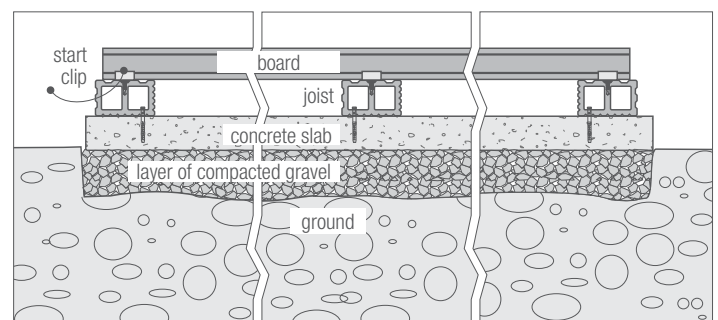

terrace view from the sides of boards

Notes:

- You shall leave a minimum expansion gap, which depends on the sum of the lengths of the boards (on the length of the terrace). A minimum of 2 mm per 100 cm of the sum of the lengths of the boards.

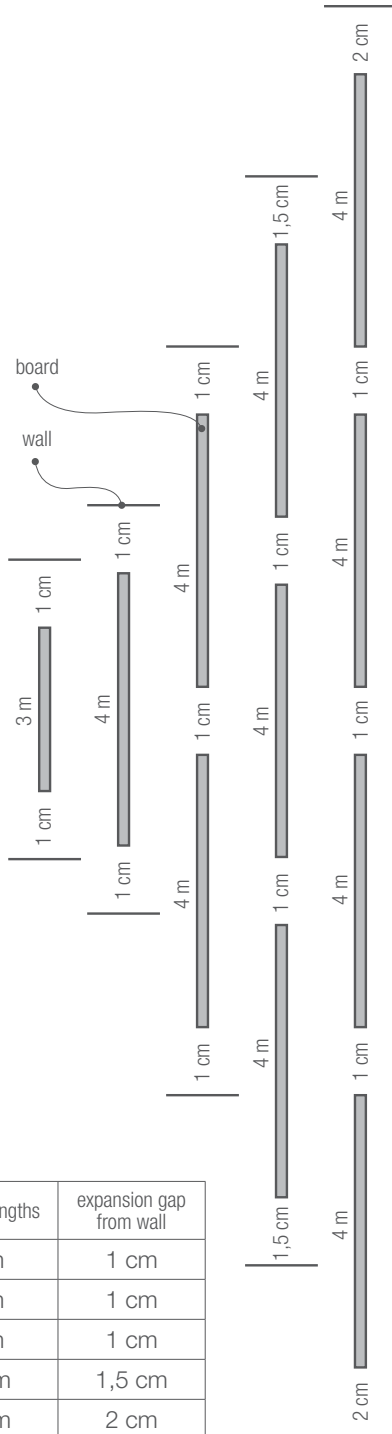

number of boards	sum of lengths	expansion gap from wall
1 pcs	3 m	1 cm
1 pcs	4 m	1 cm
2 pcs	8 m	1 cm
3 pcs	12 m	1,5 cm
4 pcs	16 m	2 cm

expansion gap between the board front edge and wall depends on the sum of the lengths of boards

The rule of thumb to be the sum of the expansion joints (including the gaps from the wall of the building, or other limitations of the edge of the terrace) was about 0.3 - 0.4% of the total length of the terrace, with them relatively evenly distributed.

The dilatation between the side of the board and the wall is dependent from the width of the terrace (the sum of the widths of the boards) and from there the length of the joists. It is defined by the same principles as in case of boards. It is counted in the same way as a frontal dilation: minimum 2 mm per 100 cm of the sum of the width of the boards

- When joists are joined using a butt joint, pay attention to leave a 0.5 cm expansion gap. The ends of the boards must rest on separate joists and be secured by separate clips.

In the case of butt joining the boards, make sure that there is an expansion gap of 1 cm between them. The ends of the boards must rest on separate joists and be fastened with separate clips.

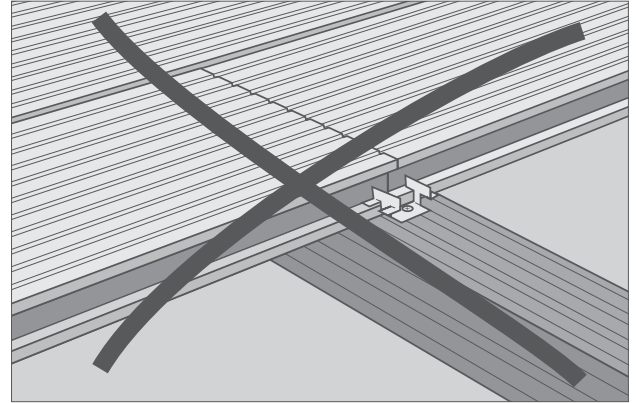

improperly made butt joint of 2 boards

- Fix clips to the joist using stainless steel self-drilling screws (they are included to the mounting kit with clips). When fixing a board in a clip, make sure it is pushed against stop. There shall be no free space between the board and the clip. This allows you to obtain a uniform expansion gap between the boards of 0.5 cm.

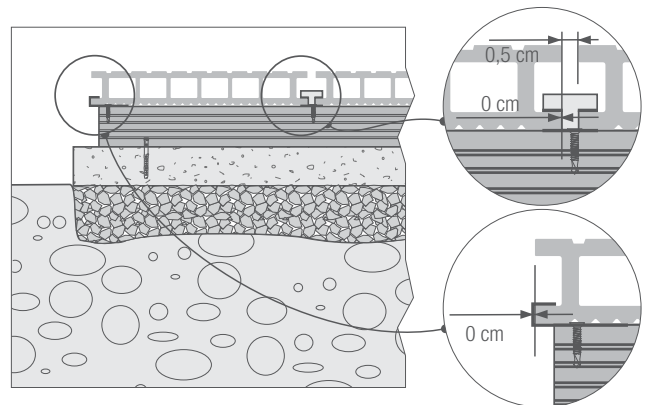

- Installation of the last board shall be made by screwing in the screw at an angle.
- The front of the board shall not protrude over the joist by more than 5 cm.
- During the period of use due to the working of the boards, the expansion joints between individual boards may vary, depending on the conditions of use and exposure.

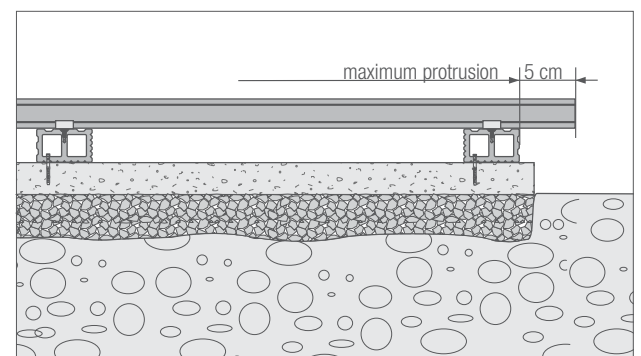

maximum protrusion of board over joist is 5 cm

TERRACE EDGE FINISHING

Terrace edge finishing is made using:

- 1) composite profiles;
- 2) aluminium corner profile;

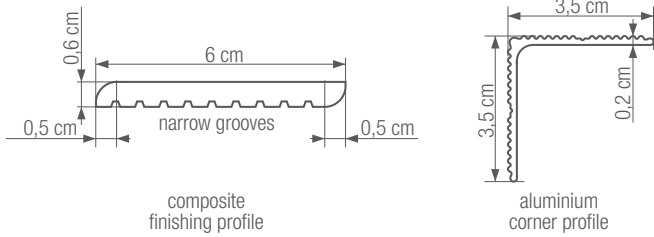

1) Finishing with a composite profile

At the corners of the terrace, cut the finishing profiles at an angle of 45°. Fix them using self-tapping screws or an elastomeric adhesive. The elliptical holes, used for the screws, are designed to provide the minimum possible movement.

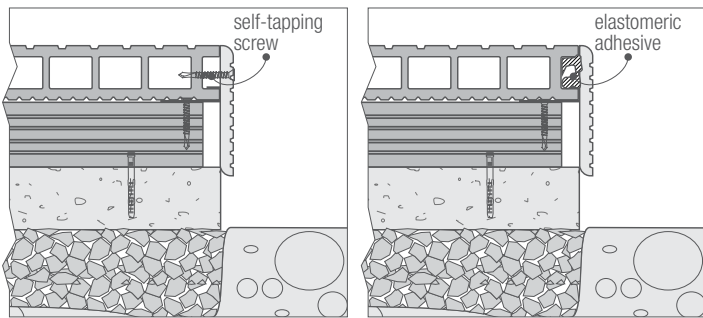

profile installation using self-tapping screws

profile installation using elastomeric adhesive

On the face of the board, fix the finishing profile to the side surface of the joist. Leave the expansion gap of 0.2 cm between the finishing profile and the front surface of the board. In addition, lower the profile by 0.1 cm from the upper surface of the board. The board elongates with increasing temperature and humidity and lack of this expansion gap may cause the profile to be torn off.

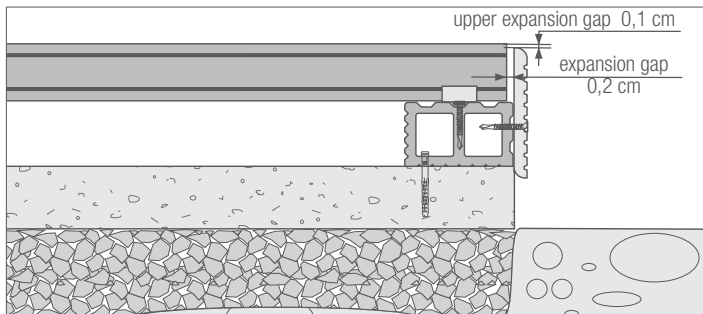

expansion gap 0.2 cm between composite finishing profile and board front surface

On the side of the board, fix the finishing profile to the side surface of the board. Leave the expansion gap of 0.5 cm between the finishing profile and the front surface of the joist. The joist elongates with increasing temperature and humidity and lack of this expansion gap may cause the profile to be torn off.

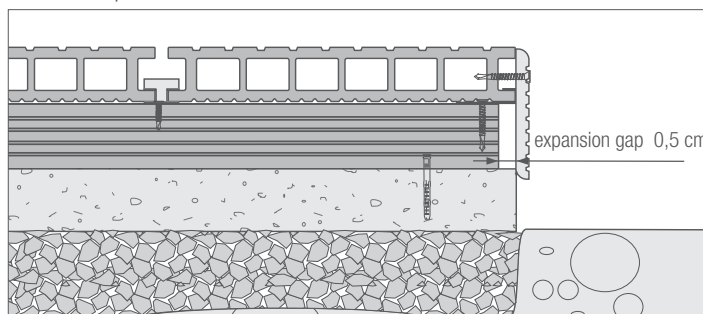

expansion gap 0.5 cm between composite finishing profile and joist front surface

2) Finishing with an aluminium corner profile

Installation of aluminium corner profiles is very similar to the composite finishing profiles.

At the corners of the terrace, cut the corner profiles at an angle of 45°. Fix them using self-tapping screws or an elastomeric adhesive.

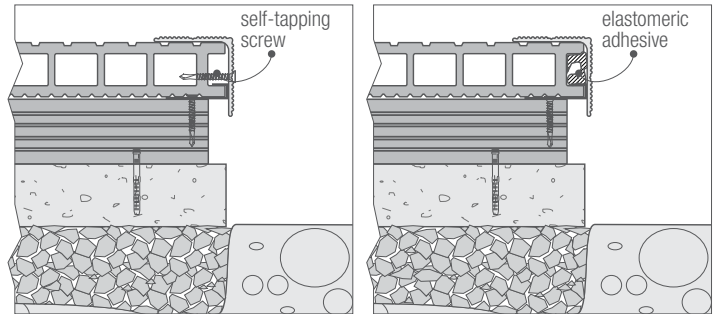

profile installation using self-tapping screws

profile installation using elastomeric adhesive

On the face of the board, fix the corner profile to the side surface of the joist. Leave the expansion gap of 0.5 cm between the corner profile and the front surface of the board. The board elongates with increasing temperature and humidity and lack of this expansion gap may cause the profile to be torn off.

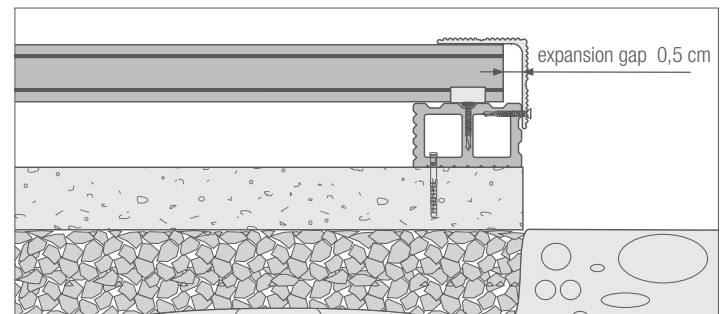

expansion gap 0.5 cm between aluminium corner profile and board front surface

On the side of the board, fix the corner profile to the side surface of the board. Leave the expansion gap of 0.5 cm between the corner profile and the front surface of the joist. The joist elongates with increasing temperature and humidity and lack of this expansion gap may cause the profile to be torn off.

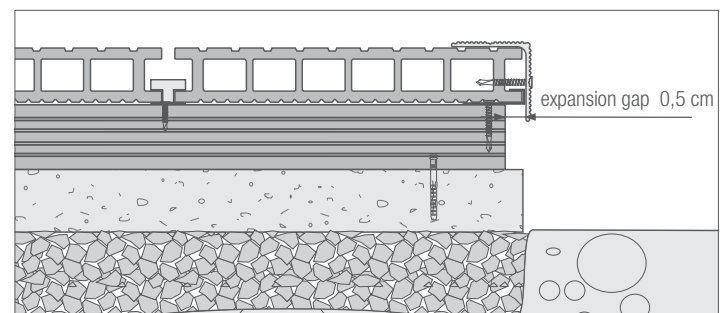

expansion gap 0.5 cm between aluminium corner profile and joist front surface

STORAGE AND MAINTENANCE

- During storage, GAMRAT composite profiles (boards, joists and profiles) shall be protected from the weather (roofing, shelters).
- To avoid deformation to their shape, they shall be stored lying flat and stable.
- GAMRAT composite profiles (boards, joists and profiles) do not require maintenance, waterproofing and painting. They are resistant to water, do not rot, do not swell. In addition, they are resistant to weather conditions, low temperatures and pests (e.g. bark beetles, termites).

CLEANING AND MAINTENANCE OF GAMRAT COMPOSITE PROFILES:

- Cleaning the composite boards is very easy and does not require any special measures. Ordinary household measures are adequate. The best cleaning results are obtained with high pressure water (at maximum of 100 bar), cleaning in the direction of board grooves.
- For cleaning, do not use solvents and cleaning machines.
- Stains of grease or oil must be removed as soon as possible, not allowing them to dry, using a basic detergent.
- In case of particularly strong soiling, use copper wire brush or sandpaper of fine granulation and clean in the direction of the board grooves. These activities shall be done very carefully so as not to damage or change the groove dimensioning.
- To ensure adequate water drainage and air flow, you shall clean the gaps between boards not allowing them to clog.
- The composite wood material is very easy to maintain, but it is worth to make maintenance regularly.
- Sweeping the terrace can prevent the formation of mould. You shall also remember to periodically sweep the area under flower pots and boxes to prevent absorbing moisture and getting dirty.
- A composite board when exposed to UV rays and water is subject to a natural process of changing its colour. This has no effect on its life and is not a product defect and does not constitute grounds for a complaint.
- We recommend sprinkling the surfaces of terrace boards that have become icing with expanded clay due to safety reasons.
- In the case of using other anti-icing agents for GAMRAT composite boards, each time the manufacturer of these boards should be consulted.

CLEANING AND MAINTENANCE OF GAMRAT ELEGANCE BOARD 140X25:

- Cleaning the composite boards is very easy and does not require any special measures. Everyday dirt could be removed by lukewarm water and household detergents. Surface cleaning with high-pressure washer is allowed with maximum 150 bar, at the minimum distance from the cleaned surface 20 cm.
- For cleaning, do not use abrasive agents, solvents, polishing pastes nor waxes.
- Stains of grease or oil must be removed as soon as possible, with basic detergents. Stains should not be allowed to dry.
- In case of particularly strong soiling, use soft sponge or soft brush.
- Please remember that Gamrat Elegance board 140x25 is wood composite, and it is worth taking care of it.

FINAL REMARKS

These guidelines are informative and illustrative and are intended to familiarize you with the methods of assembling our terrace boards and describe some possible ways of making the substructure using materials available in our offer or using substitute for commonly available materials in construction. When constructing terraces by professional companies (contractors), it should be remembered that each time the place of installation, the conditions of building the environment, the types of substrate will be different. In execution and design construction of the terrace, the materials used for the construction of load-bearing structures and foundations, manufacturing technologies, the place and conditions of use of the terrace and the available art and knowledge of general construction. In addition, they must comply with standards and regulations construction and designed by the builder using materials that meet these conditions. According to applicable law, the contractor provides a guarantee for the performance of the service. Compliance with these guidelines cannot replace full knowledge in the field of construction terraces of contractors specializing in this type of construction activity



Gamrat WPC





DECKING BOARD 185 X 20 MM

INSTALLATION AND MAINTENANCE RECOMMENDATIONS

MATERIALS

The offer includes the following basic materials:

NAME	PICTURE	DIMENSIONS (mm)
FULL TERRACE BOARD (composite profile)		20 x 185 x 3000 or 20 x 185 x 4000 or lengths on order
JOIST (aluminum profile)		36,4 x 24 x 4000
HIGH JOIST (aluminum profile)		39 x 50 x 4000
FINISHING STRIP „L” SHAPE (ANODIZED)		35 x 35 x 3600
COMPOSITE FINISHING PROFILE (composite profile)		60 x 6 x 3000
WPC FINISHING STRIP „L” SHAPE		35 x 60 x 3000

NAME	PICTURE	DIMENSIONS (mm)
MOUNTING CLIPS		Kit for 2 m ² 32 pcs of mounting clips 3 pcs of start clips
		Kit for 10 m ² 160 pcs of mounting clips 15 pcs of start clips
MOUNTING CLIPS 6 mm		Kit for 2 m ² 32 pcs Kit for 10 m ² 160 pcs
GAMRAT WPC ABS POLYMER CLIPS with SCREW 6mm		Kit for 2 m ² 32 pcs Kit for 10 m ² 160 pcs
TORX SCREW		27 x 3,8
TORX T15 50 mm		-

GAMRAT composite profiles are high quality materials containing selected meal in its composition wood and plastic (PVC) with the necessary additives. Elements these are only for making terraces and cannot be used for other construction purposes without execution of the project by persons authorized to do so. Gamrat also offers various types of leveling elements or giving the terrace an appropriate slope by raising it to the required height.

GAMRAT also offers different kinds of elements for levelling or obtaining a proper decline of a terrace by raising it to the required height.

Colouring

In the first period of use, composite profiles under the influence seasonal conditions. The color stabilizes after a few months reaching final saturation. Unbrushed boards after During the seasoning period, they undergo a matting process, which makes them visually closer for the brushed version. Due to the content of wood fibers, individual composite profiles, especially those from different production batches, may differ in color. Colors and surface finishes may be different in different deliveries. This does not affect their durability and this is not a product defect. Before proceeding with the assembly, you must visually assess the appearance of composite profiles whether they are free from defects. To achieve a natural effect, composite boards must be moved before installation, remembering the brushing direction

Substrate preparation

Terraces, stairs, communication paths made of composite profiles Gamrat is mounted on a previously prepared substrate, the implementation of which should be in accordance with the current knowledge and building regulations. Very often a preparation project is necessary substrate to maintain maximum future safety users. The execution of the substrate is carried out at the sole responsibility contractors and the information provided below is for reference only informative.

This manual has been prepared for standard board lengths and joists of 3 m.

The most common solutions include:

- 1) Concrete substrate, reinforced concrete;
- 2) Substrate on the ground;
- 3) Substrate on a balcony or inverted roof structure with waterproofing.

In any case, regardless of the type of substrate and the joist used for the construction of terrace boards, joist spacing which the directly mounted boards will rest on, must be equal to maximum 40 cm "in the light". At the same time, it is necessary to ensure that the board is fastened with clips as much as possible every 45 cm. At the beginning and end of the planks to provide extra stabilization and proper work, the first row of joists should be compacted and this distance should be 20 cm „in the light”. The structure should be closed with a frame within the terrace outline.

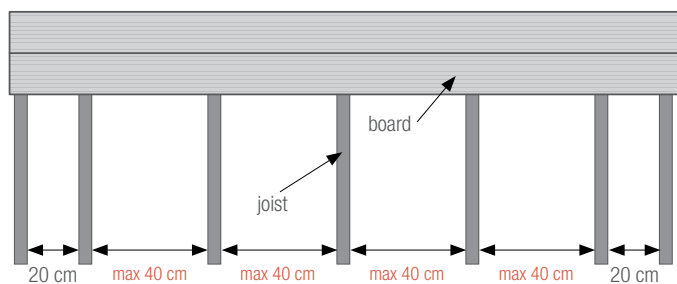

spacing of joists

1) CONCRETE SUBSTRATE, REINFORCED CONCRETE:

- The terrace is mounted on joists attached to the substrate.

Lay joists on a concrete slab (do not embed them in the concrete), fixing with concrete dowels or elastomeric adhesive. It is allowed to install joists arranged vertically using an elastomeric adhesive (only on flat surfaces, adjacent on the entire length of the joist to the ground).

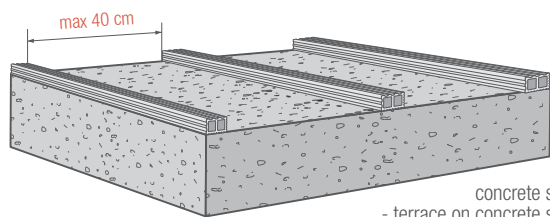

concrete substrate
- terrace on concrete substrate

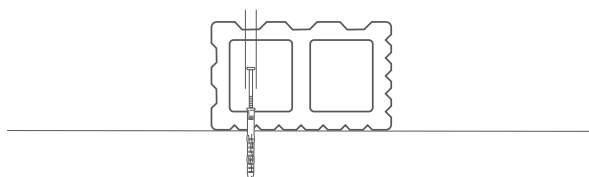

The joists can also be placed on a steel, wooden or aluminum structure or on plastic supports or concrete cubes. All these types of supports must be permanently attached to the ground. The joist must be fixed (drilled, with a dowel or using 90o carpentry joints). Maximal the distance between the support points of the joists it's 35cm. The ground must be flat and stable with a minimum slope of 1% from the outside of the building. Such an inclination of the terrace affects optimal drainage of water from its surface.

2a) SUBSTRATE ON GROUND:

- The terrace is installed on concrete foundations with a wooden or metal structure with a higher load capacity than the joist.

In this case, drill holes to a depth below the frost line ground. Depending on the region, it is about 1.0 m deep - 1.2 m. It is advisable to reinforce the openings with wire and pour concrete. Above in the center of the holes made, e.g. cardboard ones should be placed concrete covers to the height of the planned terrace (taking into account the thickness of the joist and the thickness of the board), make the whole thing in the recommended slope terrace (min. 1%) and pour concrete. Distances between each pillars/joist support points depends on the type used material from which the construction will be made. Usually used such a wooden or metal joist profile so that the distance between concrete pillars could be approx. 0.6 m.

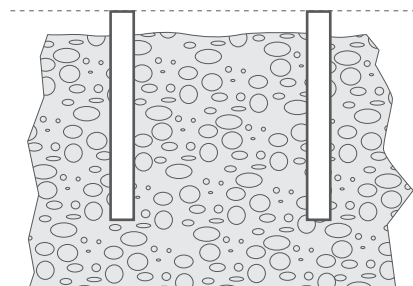

substrate on ground
- terrace on concrete supports

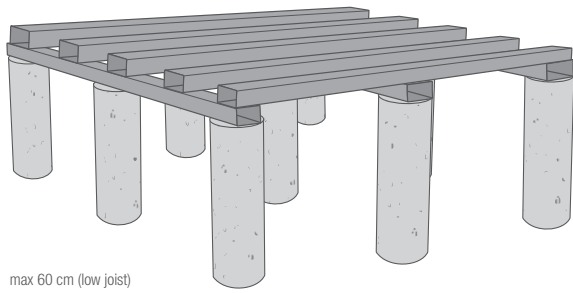

max 60 cm (low joist)
or 100 cm (high joist)

substrate on ground
- terrace on concrete supports and metal structure



low aluminum joist
- spacing of supports max. every 60 cm



high aluminum joist
- spacing of supports max. every 100 cm

2b) SUBSTRATE ON GROUND:
• Terrace installed on concrete slabs.

We assemble the terrace on concrete slabs. In order to make the substrate in this way, the layer must be removed soil to a depth of approx. 20 - 30 cm, and put gravel in this place. Compact the whole in a way that prevents further settling of stones. Concrete slabs should be placed on the prepared substrate such a distance apart that there is free space between the points support of the joists did not exceed 35 cm. The joists must be on permanently attached to concrete slabs. The weight of the concrete slabs it must be large enough to ensure adequate stability and maintenance construction.

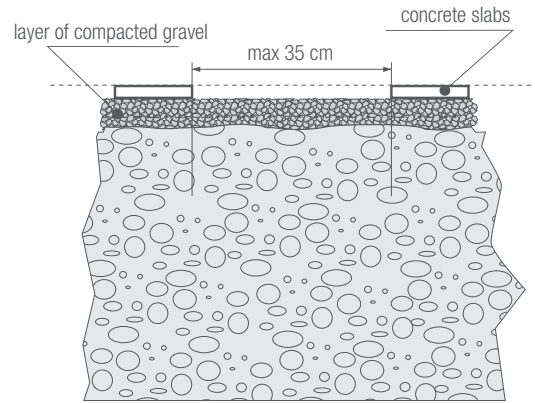

substrate on ground
- terrace on concrete slabs

3) SUBSTRATE ON A BALCONY OR STRUCTURE OF AN INVERTED ROOF WITH WATERPROOFING:

- Install the floating terrace on a metal truss.

In the case of floating terraces, where there is no possibility to penetrate directly into the ground, which takes place where horizontal waterproofing is made, e.g. balconies, garages, etc. Boards must be laid on a suitable self-supporting structure in the form truss made of steel or aluminum joists o a suitable profile that will take over the work of the terrace and stiffen it him. The first layer of joists on the lower or most often on the upper ones points of support in the form of adjustable brackets or concrete blocks, properly leveled. Next the second cross layer of steel or aluminum joists with preservation spacing under the boards max 40 cm between. In in this case, the compaction of the first row is particularly important joists at a spacing of 20 cm. This is to provide extra stabilization and operation of a structure that is not permanently attached to the ground. We remember further about the requirement to fasten the board with clips maximum every 45 cm.

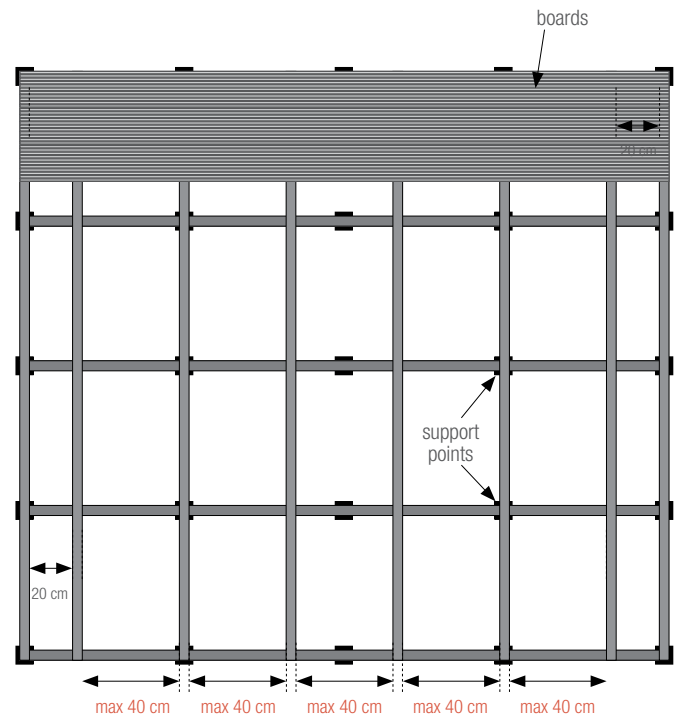

Floating terrace on a metal truss

Note:

• When preparing the substrate, pay attention to looseness drainage of water outside the terrace area. This applies to both terraces made at ground level as well as above-ground terraces. In order to facilitate the drainage of water, it is recommended to make a slope from the building at least 1%, i.e.: 1 cm per 1 m. This applies to both terrace boards, as well as the structures on which they are mounted joists.

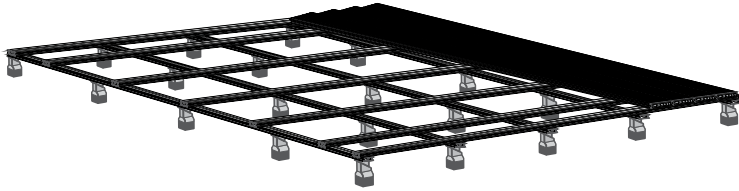

Floating terrace on a metal truss laid on levelling plastic supports

1) HORIZONTAL AND VERTICAL POSITIONING OF JOISTS AND EXPANSIONS GAPS

Joists shall be laid parallel to each other (except for cutting terraces at an angle of 45°). It is allowed to lay joists in the horizontal position, which causes the terrace to be additionally raised by about 3 cm or in the vertical position, which causes the terrace to be additionally raised by about 5 cm (joist of dimensions 3,9 x 5 cm).

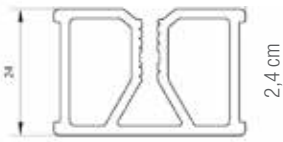

low aluminum joist



high aluminum joist

Laying should be done so that the joists lie flat and wide grooved up. These grooves are prepared so that the mounting clips fit in the grooves of the profile, which will be helpful in the further assembly stage. Be sure to leave between the wall and the joist 1-2 cm. To ensure good drainage of surface water under the terrace, a gap of 1 cm should be made at the frontal one joining joists. These expansion joints are essential for proper behavior of the elements during use and for free drainage of water under the boards.

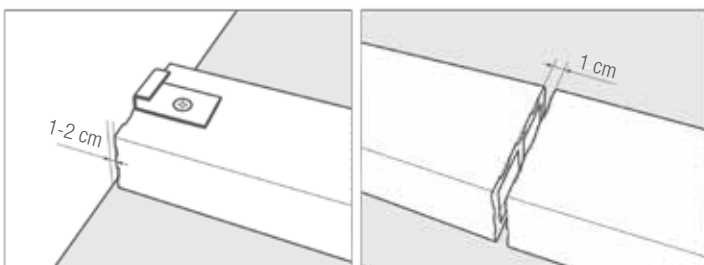

aluminum joists

2) SPACING AND ARRANGEMENT OF JOISTS

Maximum distance between joists (board support points) must not exceed 40 cm at any point, and each a single joist, regardless of its length, must have a minimum 3 support points not exceeding 60 cm.

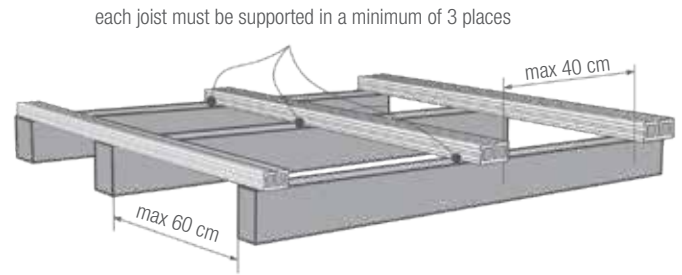

spacing of joists

If it is necessary to join the boards face-on or to make them bevels of the terrace, remember to install an additional one joist so that the ends of each plank rest on a separate one joists and were attached with separate clips.

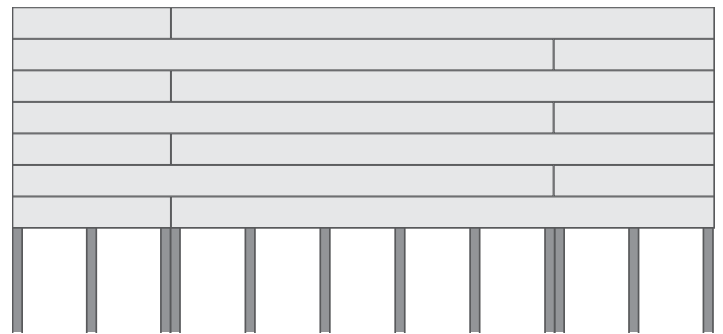

arrangement of joists when using butt joints of boards - terrace with a staggered arrangement

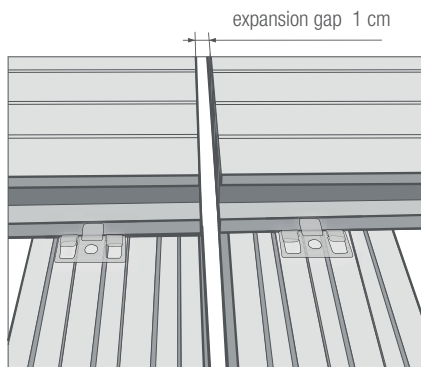

boards joined using a butt joint and supported by two joists

* All mounting clips from the Gamrat WPC offer can be used interchangeably.

Notes:

- In any case, regardless of the structure of the terrace foundation it is recommended to use only aluminum joists.
- Please note that the maximum distance between joists (points board support) must not exceed 40 cm from the edge adjacent joists (i.e. clearance between joists) and the distance between clips must not exceed 45 cm.
- For heavy traffic (e.g.: pedestrian communication road, stairs) or occurrence of significant concentrated forces on the terrace (e.g.: placing heavier objects on the terrace) the distance between support points of the joists and the distances between them should be thickened accordingly.

1) TYPES OF GROOVES AND ARRANGEMENT OF BOARDS

Gamrat composite profile - 18.5 cm wide terrace board is a one-sided product. On the usable area it has characteristic groove shape. On the usable surface, it has grooves of a characteristic shape.

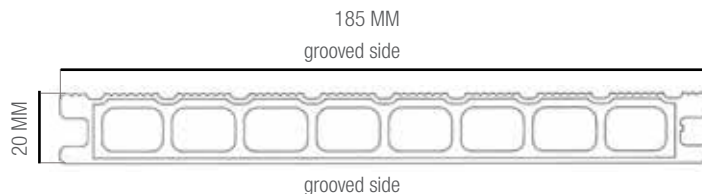

On one side of the terrace board there is a printed one an inscription clearly identifying the product, and a tab on the other – marker. When assembling, make sure that the inscription or the marker was always on one side of the assembled terrace. This ensures that the boards will be laid with this in mind brushing direction. This arrangement minimizes the - the occurrence of shade differences after installation and over time using

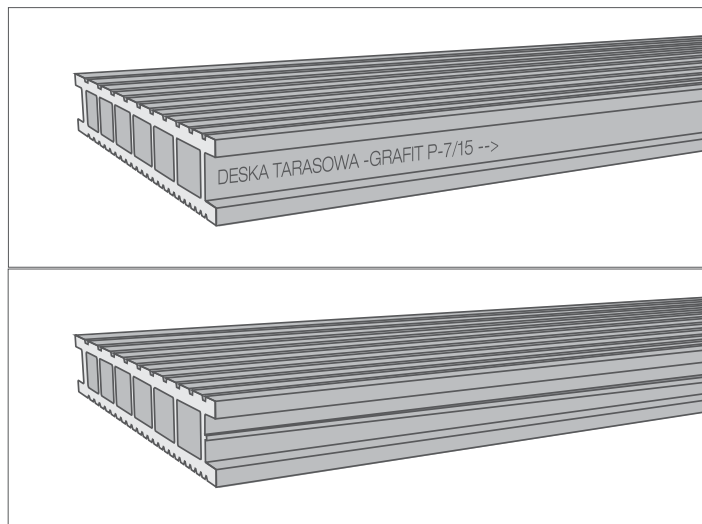

2) FASTENING BOARDS

Fastening boards to joists is done using the supplied mounting kit. The set includes screws, start clips – for installing the first board, and mounting clips – for fastening subsequent boards.

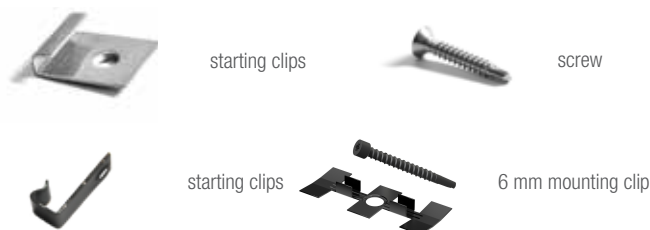

LAYING TERRACE BOARDS

Start installing a board from fastening start clips to the joist. You shall leave an expansion gap of min. 1-2 cm between the board and the wall.

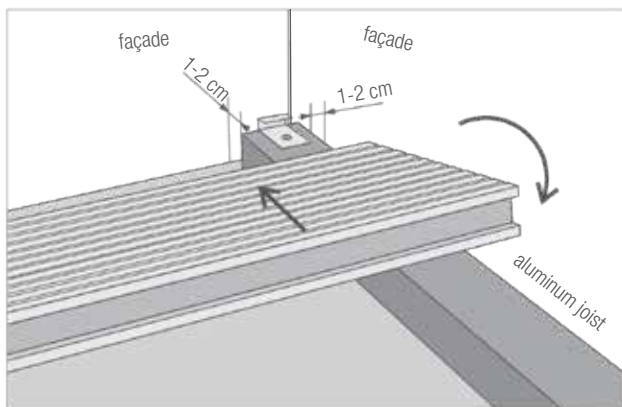

installation of the first board with a start clip

After fastening the start clips, place a board to have its lower tongue properly fixed by the start clip. Push the board into its place and screw in the second edge of the board using a mounting clip. It should be noted that in order to facilitate the installation, the hole in the clip is made as an eccentric one. This allows you to freely screw the clip in before placing the next board.

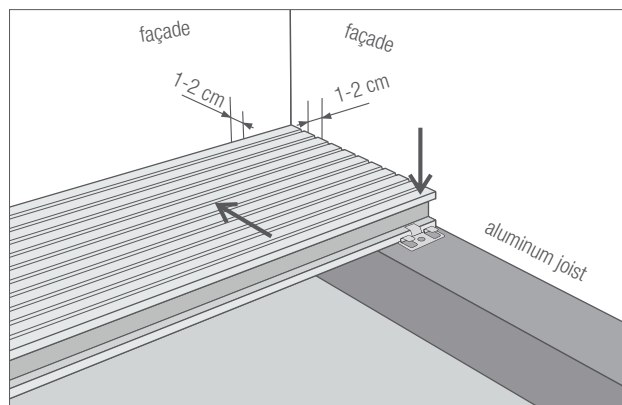

installation of the first board with a mounting clip

* All mounting clips from the Gamrat WPC offer can be used interchangeably.

Clips are designed so that there is an expansion gap of 0.5 cm between the subsequent boards.

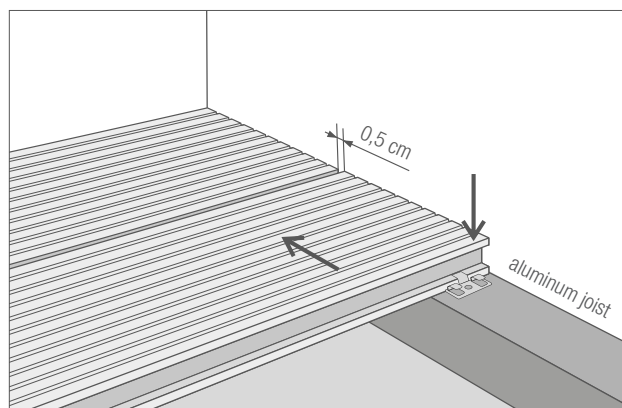

installation of a subsequent board with a mounting clip

* All mounting clips from the Gamrat WPC offer can be used interchangeably.

In the event of connecting boards using a butt joint, pay attention to that the expansion gap there between is 1 cm.

LAYING TERRACE BOARDS

The ends of the boards must rest on separate joists and be secured by separate clips. For a better appearance, it is recommended to cut off approximately 10 mm from both ends of the board before its installation, as they are slightly rounded after brushing.

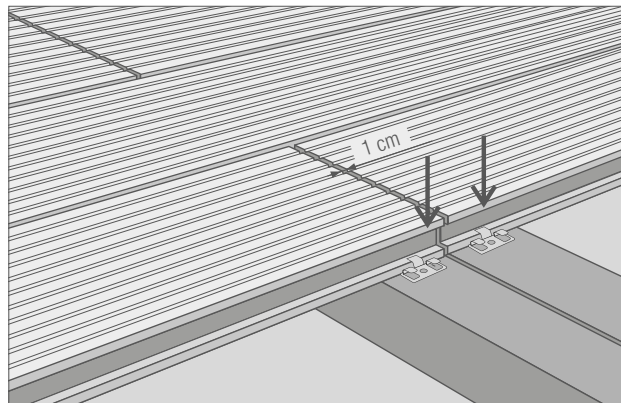

butt joint of boards on two separate joists (expansion gap 1 cm)

* All mounting clips from the Gamrat WPC offer can be used interchangeably.

The installation of the last board shall be performed by screwing the screw at an angle through the bottom edge of the board to the joist. There is a possibility of cutting a board lengthwise, crosswise and at an angle. To do this, use widely available professional tools like for cutting wood planks.

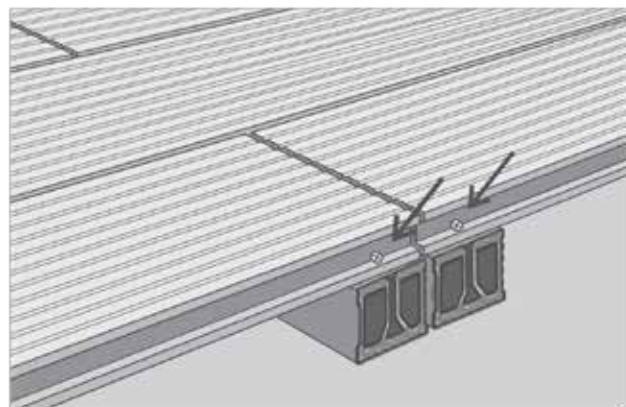

installation of the last boards with screws screwed at an angle

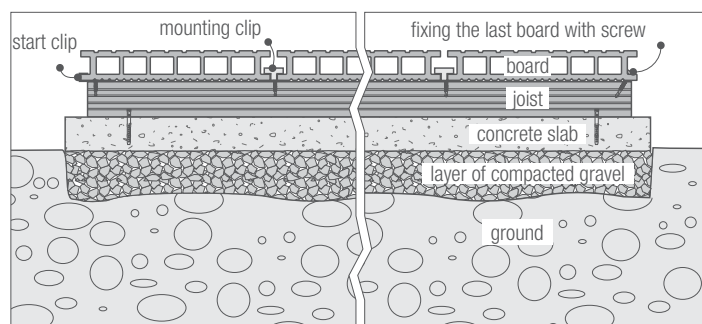

terrace view from the fronts of boards

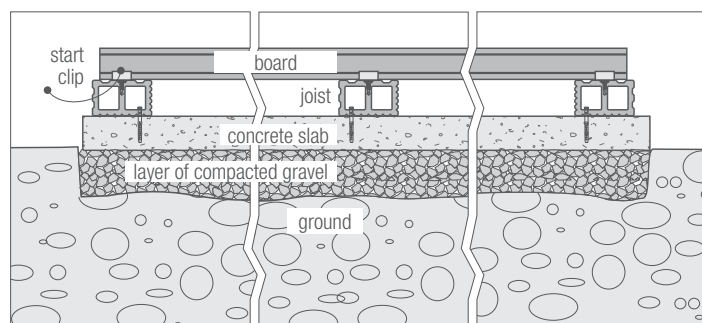

terrace view from the sides of boards

Notes:

- You shall leave a minimum expansion gap, which depends on the sum of the lengths of the boards (on the length of the terrace). A minimum of 2 mm per 100 cm of the sum of the lengths of the boards.

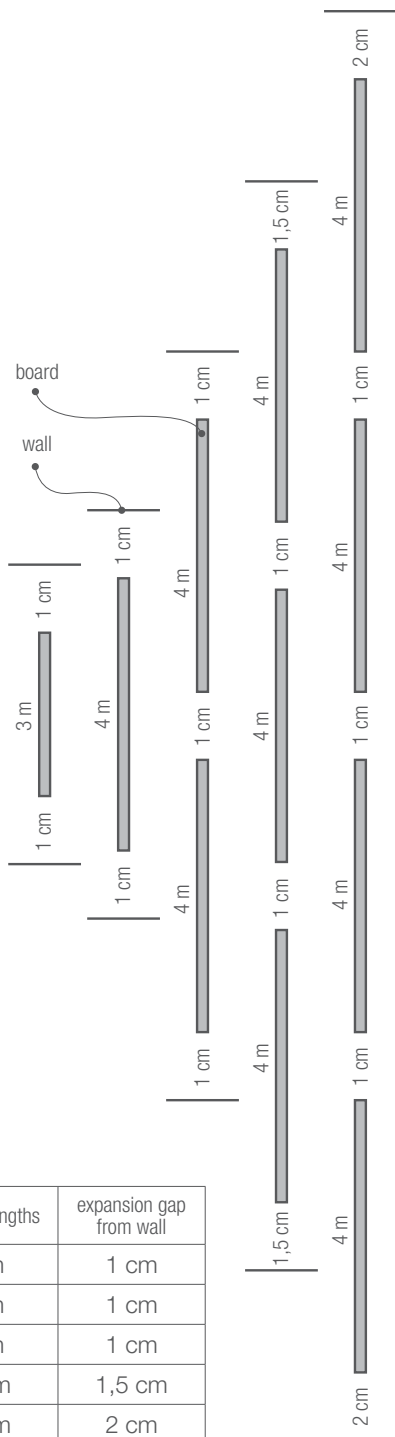

number of boards	sum of lengths	expansion gap from wall
1 pcs	3 m	1 cm
1 pcs	4 m	1 cm
2 pcs	8 m	1 cm
3 pcs	12 m	1,5 cm
4 pcs	16 m	2 cm

expansion gap between the board front edge and wall depends on the sum of the lengths of boards

The rule of thumb to be the sum of the expansion joints (including the gaps from the wall of the building, or other limitations of the edge of the terrace) was about 0.3 - 0.4% of the total length of the terrace, with them relatively evenly distributed.

The dilatation between the side of the board and the wall is dependent from the width of the terrace (the sum of the widths of the boards) and from there the length of the joists. It is defined by the same principles as in case of boards. It is counted in the same way as a frontal dilation: minimum 2 mm per 100 cm of the sum of the width of the boards

- When joists are joined using a butt joint, pay attention to leave a 0.5 cm expansion gap. The ends of the boards must rest on separate joists and be secured by separate clips.

In the case of butt joining the boards, make sure that there is an expansion gap of 1 cm between them. The ends of the boards must rest on separate joists and be fastened with separate clips.

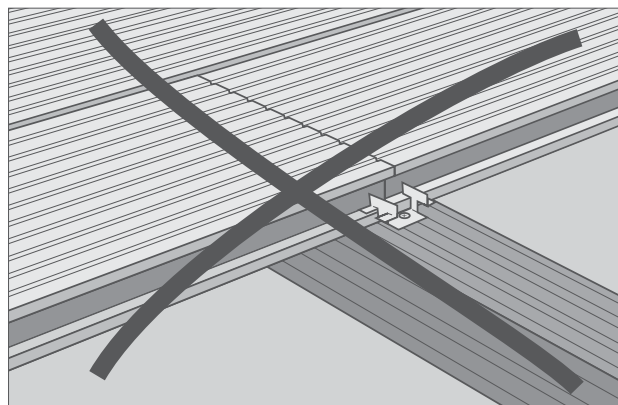

improperly made butt joint of 2 boards

- Fix clips to the joist using stainless steel self-drilling screws (they are included to the mounting kit with clips). When fixing a board in a clip, make sure it is pushed against stop. There shall be no free space between the board and the clip. This allows you to obtain a uniform expansion gap between the boards of 0.5 cm.

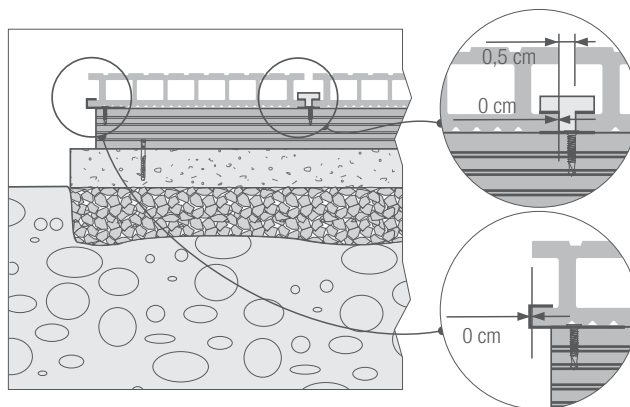

- Installation of the last board shall be made by screwing in the screw at an angle.
- The front of the board shall not protrude over the joist by more than 5 cm.
- During the period of use due to the working of the boards, the expansion joints between individual boards may vary, depending on the conditions of use and exposure.

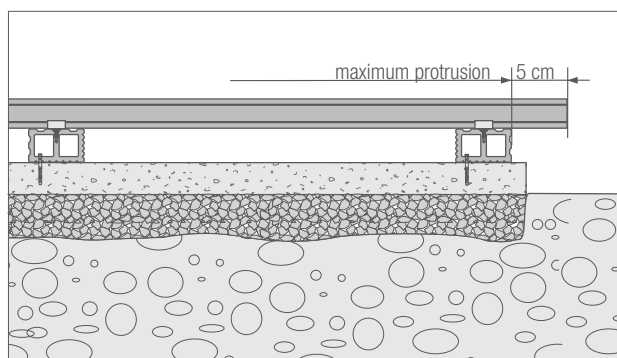

maximum protrusion of board over joist is 5 cm

TERRACE EDGE FINISHING

Terrace edge finishing is made using:

- 1) composite profiles;
- 2) aluminium corner profile;

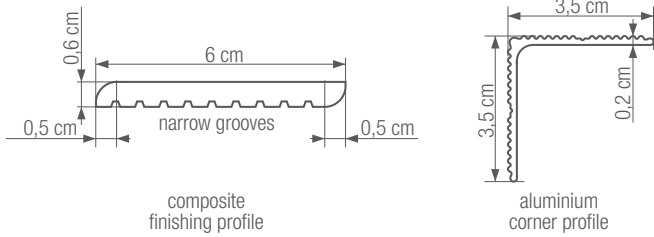

1) Finishing with a composite profile

At the corners of the terrace, cut the finishing profiles at an angle of 45°. Fix them using self-tapping screws or an elastomeric adhesive. The elliptical holes, used for the screws, are designed to provide the minimum possible movement.

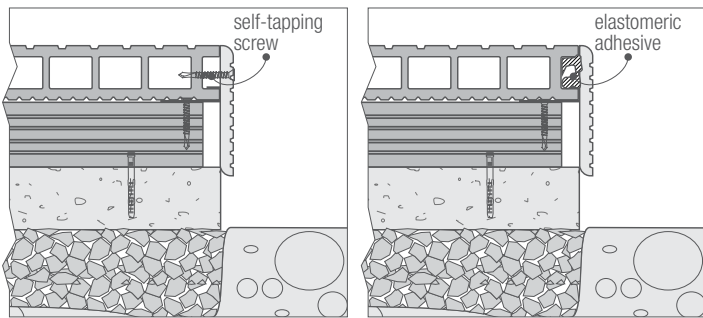

profile installation using self-tapping screws

profile installation using elastomeric adhesive

On the face of the board, fix the finishing profile to the side surface of the joist. Leave the expansion gap of 0.2 cm between the finishing profile and the front surface of the board. In addition, lower the profile by 0.1 cm from the upper surface of the board. The board elongates with increasing temperature and humidity and lack of this expansion gap may cause the profile to be torn off.

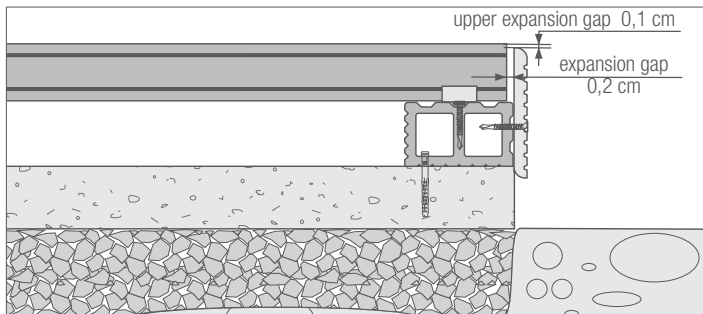

expansion gap 0.2 cm between composite finishing profile and board front surface

On the side of the board, fix the finishing profile to the side surface of the board. Leave the expansion gap of 0.5 cm between the finishing profile and the front surface of the joist. The joist elongates with increasing temperature and humidity and lack of this expansion gap may cause the profile to be torn off.

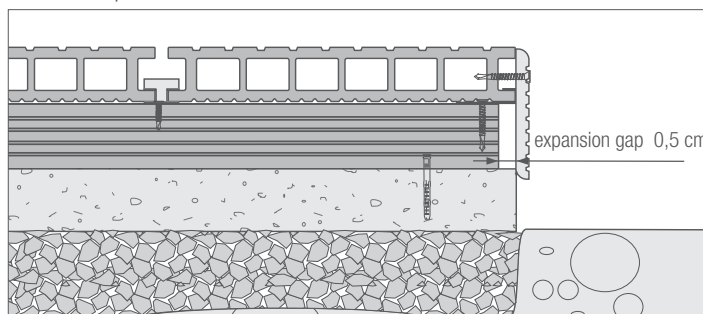

expansion gap 0.5 cm between composite finishing profile and joist front surface

2) Finishing with an aluminium corner profile

Installation of aluminium corner profiles is very similar to the composite finishing profiles.

At the corners of the terrace, cut the corner profiles at an angle of 45°. Fix them using self-tapping screws or an elastomeric adhesive.

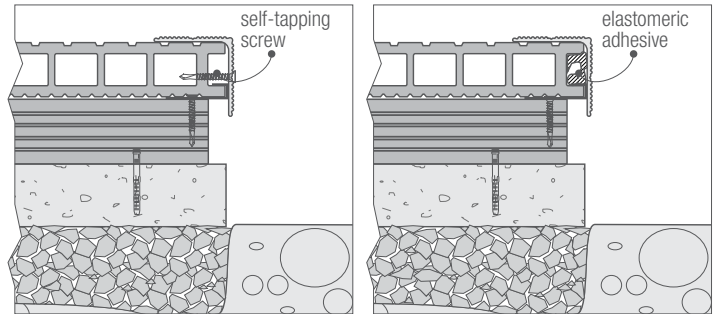

profile installation using self-tapping screws

profile installation using elastomeric adhesive

On the face of the board, fix the corner profile to the side surface of the joist. Leave the expansion gap of 0.5 cm between the corner profile and the front surface of the board. The board elongates with increasing temperature and humidity and lack of this expansion gap may cause the profile to be torn off.

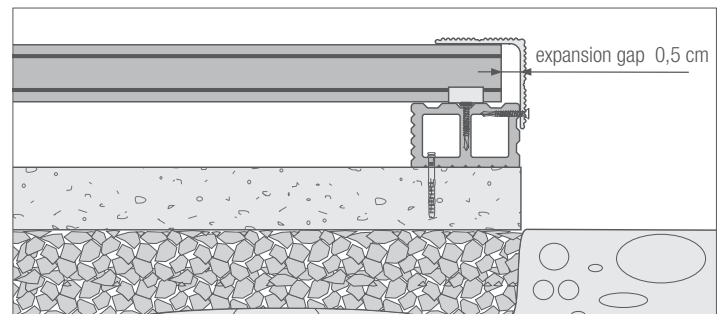

expansion gap 0.5 cm between aluminium corner profile and board front surface

On the side of the board, fix the corner profile to the side surface of the board. Leave the expansion gap of 0.5 cm between the corner profile and the front surface of the joist. The joist elongates with increasing temperature and humidity and lack of this expansion gap may cause the profile to be torn off.

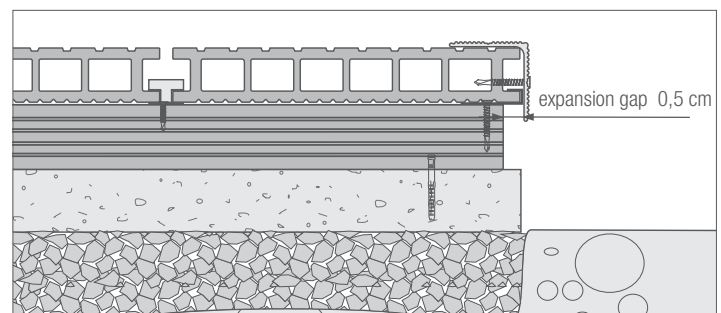

expansion gap 0.5 cm between aluminium corner profile and joist front surface

STORAGE AND MAINTENANCE

- During storage, GAMRAT composite profiles (boards, joists and profiles) shall be protected from the weather (roofing, shelters).
- To avoid deformation of their shape, they shall be stored lying flat and stable.
- GAMRAT composite profiles (boards, joists and profiles) do not require maintenance, waterproofing and painting. They are resistant to water, do not rot, do not swell. In addition, they are resistant to weather conditions, low temperatures and pests (e.g. bark beetles, termites).
- Cleaning the composite boards is very easy and does not require any special measures. Ordinary household measures are adequate. The best cleaning results are obtained with high pressure water (at maximum of 100 bar), cleaning in the direction of board grooves.
- For cleaning, do not use solvents and cleaning machines.
- Stains of grease or oil must be removed as soon as possible, not allowing them to dry, using a basic detergent.
- In case of particularly strong soiling, use copper wire brush or sandpaper of fine granulation and clean in the direction of the board grooves. These activities shall be done very carefully so as not to damage or change the groove dimensioning.
- To ensure adequate water drainage and air flow, you shall clean the gaps between boards not allowing them to clog.
- The composite wood material is very easy to maintain, but it is worth to make maintenance regularly.
- Sweeping the terrace can prevent the formation of mould. You shall also remember to periodically sweep the area under flower pots and boxes to prevent absorbing moisture and getting dirty.
- A composite board when exposed to UV rays and water is subject to a natural process of changing its colour. This has no effect on its life and is not a product defect and does not constitute grounds for a complaint.
- We recommend sprinkling the surfaces of terrace boards that have become icing with expanded clay due to safety reasons.
- In the case of using other anti-icing agents for GAMRAT composite boards, each time the manufacturer of these boards should be consulted.

FINAL REMARKS

These guidelines are informative and illustrative and are intended to familiarize you with the methods of assembling our terrace boards and describe some possible ways of making the substructure using materials available in our offer or using substitute for commonly available materials in construction. When constructing terraces by professional companies (contractors), it should be remembered that each time the place of installation, the conditions of building the environment, the types of substrate will be different. In execution and design construction of the terrace, the materials used for the construction of load-bearing structures and foundations, manufacturing technologies, the place and conditions of use of the terrace and the available art and knowledge of general construction. In addition, they must comply with standards and regulations construction and designed by the builder using materials that meet these conditions. According to applicable law, the contractor provides a guarantee for the performance of the service. Compliance with these guidelines cannot replace full knowledge in the field of construction terraces of contractors specializing in this type of construction activity



Gamrat WPC

INSTALLATION LAYOUT

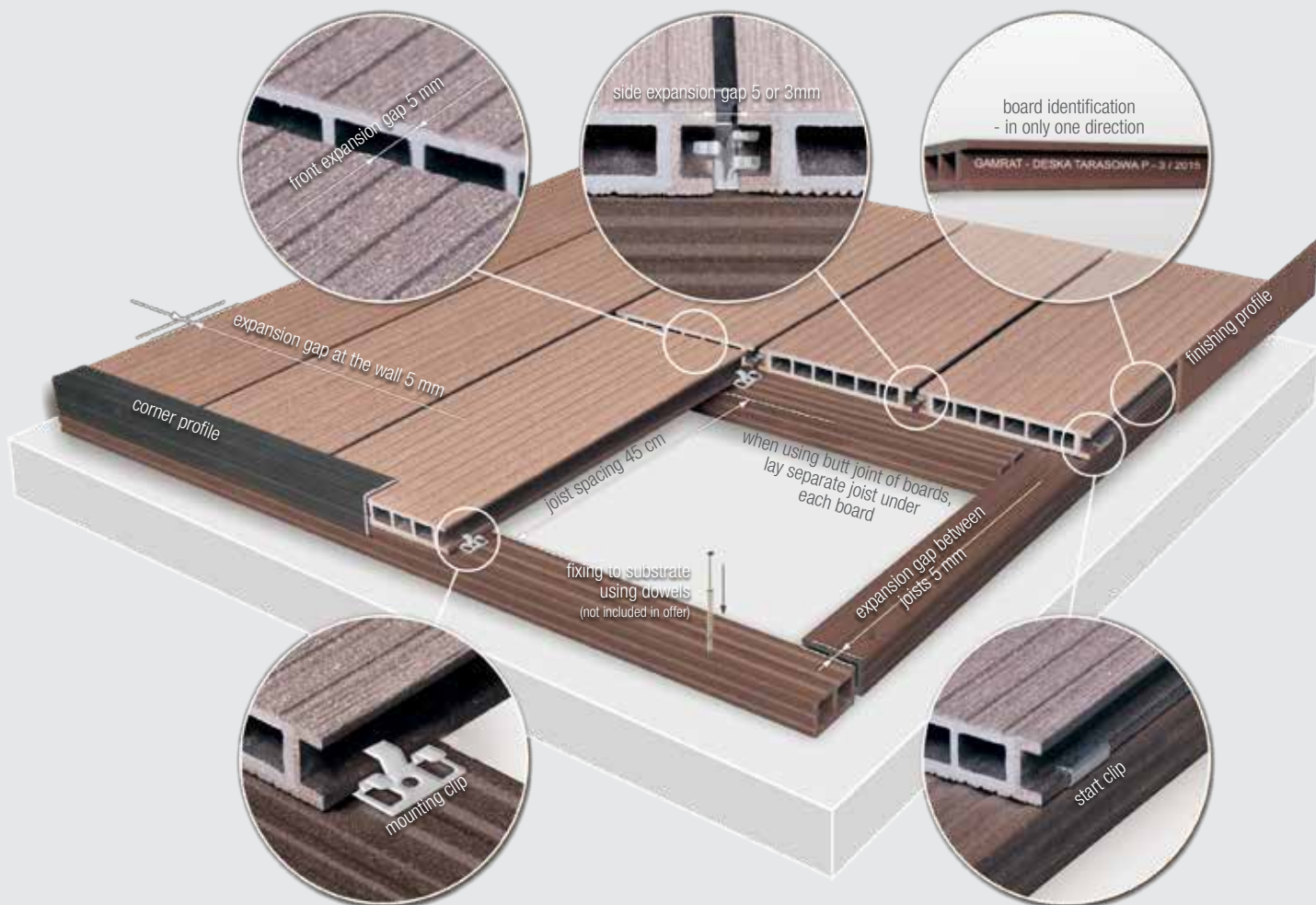

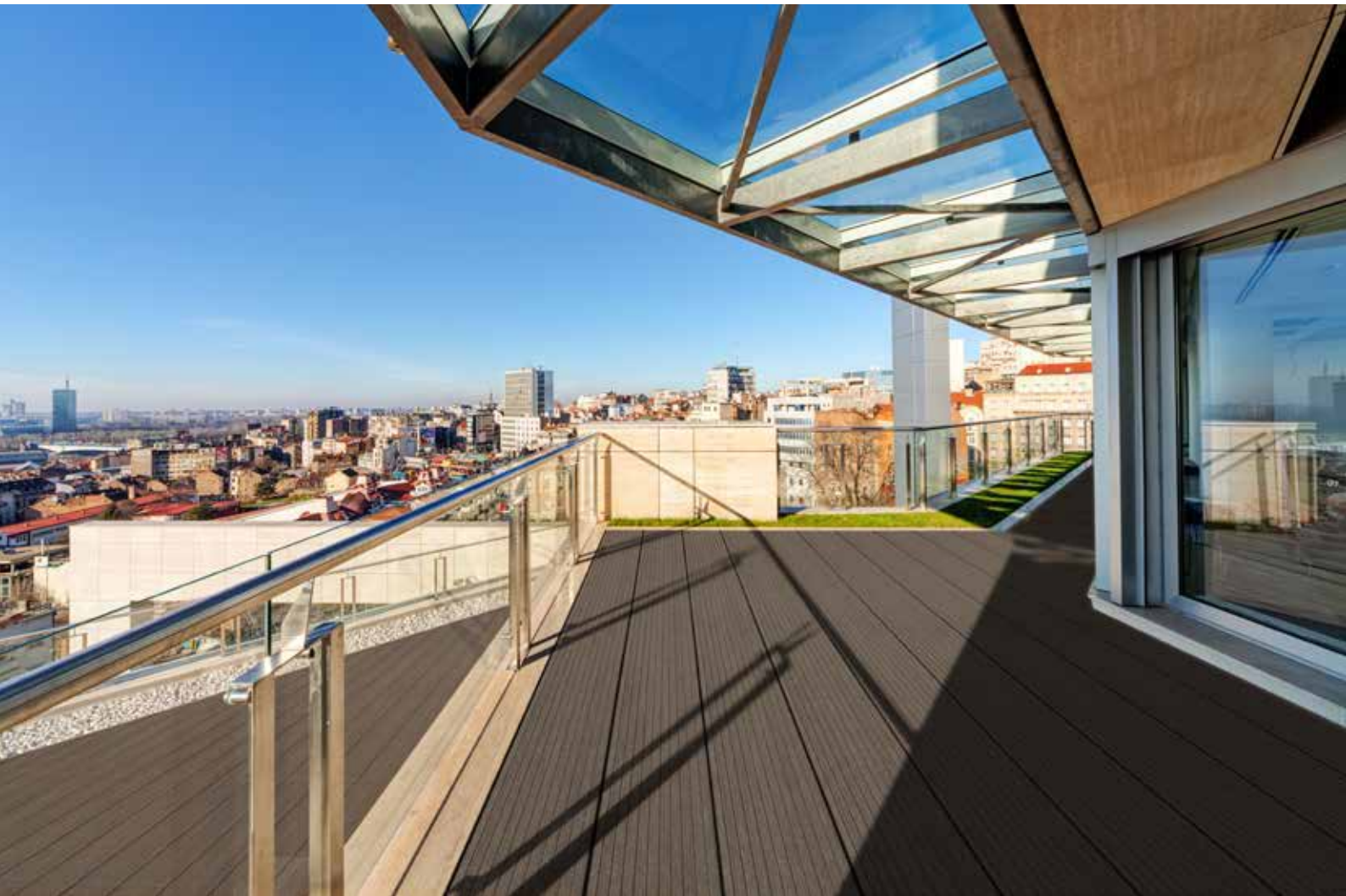

Export Department

+48 608 636 370 | wpcexport@gamrat.pl